

MULTIFARMER MF40.9CS

- ▶ Proven Merlo **winning performance** in a larger, more adept machine
- ▶ **Front or rear axle** can be locked in relation to the task to be performed - boom or 3-point linkage
- ▶ CVTronic increases torque at low speeds to **improve performance** and towing capacity
- ▶ The largest in its category, its suspended cab comes complete with **multi-function armrests**



SINCE 1964

Merlo's larger and safer MF40.9CS telehandler delivers top efficiency and performance.



MULTIFARMER MF40.9CS

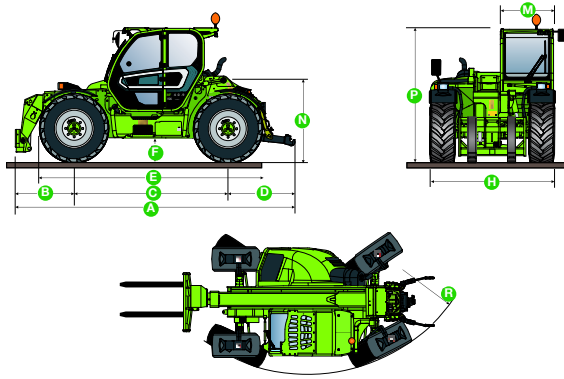

DIMENSIONS

A (mm)	5,490
B (mm)	1,290
C (mm)	2,920
D (mm)	1,280
E (mm)	4,240
F (mm)	450
H (mm)	2,360
M (mm)	1,010
N (mm)	1,630
P (mm)	2,525 (min)
R (mm)	4,080

PERFORMANCE

Unladen Weight (kg)	9,100
Maximum Load Capacity (kg)	4,000
Maximum Lift Height (m)	8.8
Capacity at Maximum Height (kg)	3,000
Maximum Reach (m)	5.9
Capacity at Maximum Reach (kg)	800
Frame Levelling (%)	±9

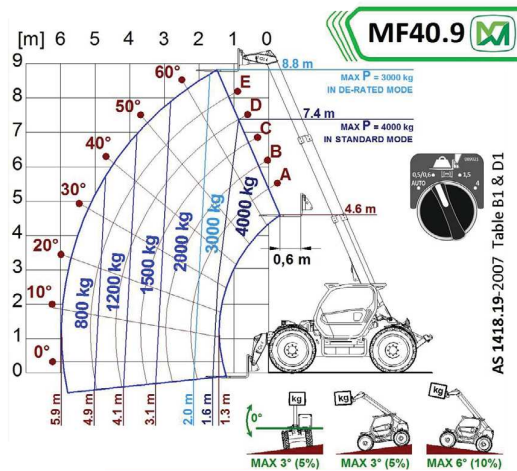

120-124 Toongabbie Road Girraween 2145 NSW Australia
For further information please call 1300 657 325 or visit merloaustralia.com.au

STANDARD SPECIFICATIONS

Engine

Turbo Engine	Duetz Tier4 Interim
Range/Cylinders	4.1/4
Engine Power (kW/HP)	115/156
Maximum Speed (km/h)	40
Fuel Tank Capacity (l)	150

Transmission

Hydrostatic Merlo EPD Transmission	Std
Speeds	CVTronic
Dual Reverse Shuttle System	Std
Pedal Inching-Control	Std
Permanent Four-Wheel Drive	Std

Brakes

Automatic Parking Brake	Std
External Dry Disc Service Brakes	Std

Tyres

Standard Tyres	500/70 R24
----------------	------------

Cab

Cab Suspension	Std
Air Conditioned Cab	Std
Air Suspension Seat	Std
FOPS (ISO 3449) and ROPS (ISO 3471) Cab	Std

Steering

All Wheel Steering	Std
--------------------	-----

Instruments

Electronic Joystick Control	Std
Merlo Dynamic Load Control (M-CDC)	Std
Reversing Camera	Std

Hydraulic System-Implement

LS Flow-Sharing Hydraulic System (bar-l/min)	210/152
BSS Hydro-Pneumatic Boom Suspension	Std
Hydraulic Oil Tank Capacity (l)	95
Auxiliary Hydraulic Service on Boom	Std

Accessories and Attachments

Tac-Lock Attachment Locking	Std
Standard Forks	Std
Fork Extensions	Optional
Digging Bucket	Optional
Re-Handling Bucket	Optional
4 x 1 Bucket	Optional
Multipurpose Bucket with Grab	Optional
Drum Clamp	Optional
Forks with Slide Protection	Optional
Handler for Single Round Bale	Optional
Rear Hydraulic Pick Up Hitch	Optional
Rotator	Optional
Crane Hook	Optional
Reduced Height Crane Jib	Optional

EXTRA SPECIFICATIONS

Mechanical PTO (540/1000)	Std
3 Point Linkage	Std
4 Rear Hydraulic Lines - 2 Floating - 2 Constant Flow	Std
Hydraulic Trailer Brakes	Std
Rear Diff Lock	Std

Merlo reserves the right to modify and update the contents of this document at any time. Information and technical data are as available at time of printing.

For current information on Merlo products please contact your Merlo dealer.

ABN 87116110751 **MER-MF40.9CS-2018**